



S-LINK-8

Splitter/Mixer



Features

- 2 Inputs / 8 Outputs in splitter mode
- 8 Inputs / 2 Outputs in mixer mode
- Individual MIX / SPLIT modes
- Individual Balance / Pan. Control
- 8 x level meters

In many applications there is always a need to split and/or to mix audio signals without sophisticated equipment.

The S-LINK-8 is an inexpensive device which implements both splitting and mixing possibilities in a very simple way. By combining its functionalities the S-LINK-8 can split and mix at the time.

For instance, the MIXLINK 8 can be transformed into an 8 IN / 2 OUT splitter or a 2 IN / 8 OUT mixer, including various combinations like the example below.

All inputs and output are distributed with balanced connectors. 6 inputs and 6 outputs feature XLR and 2 inputs and 2 outputs used 1/4" phone jacks.

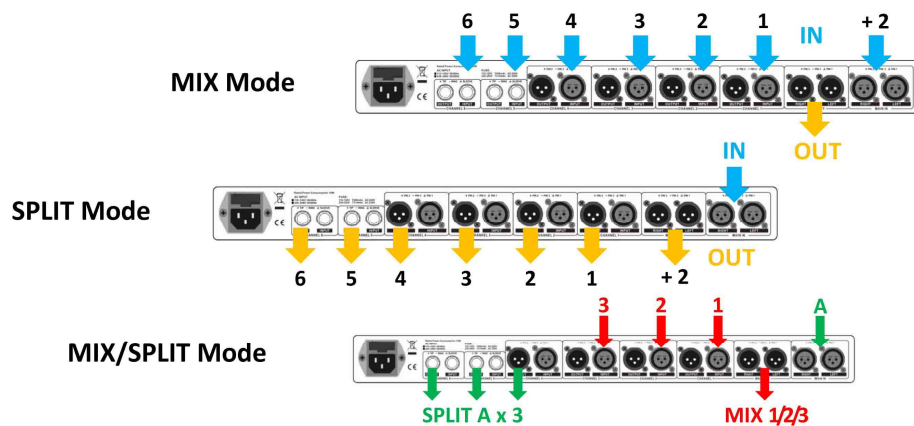

Specifications

Frequency Response	20 Hz – 22kHz ± 2dBu
Max. Input Gain	20dB CH MIC. Input - Main out (XLR, balanced) 20dB CH MIC. Input - CH. out (XLR, balanced) 20dB CH MIC. Input - Main out (unbalanced) 20dB CH MIC. Input - CH. out (unbalanced)
THD & N (1 kHz)	<0.02%
Main Voltage	220~240VAC / 110~120VAC 50/60Hz or 24VDC
Impedance	Microphone input: 50kΩ, Unbalanced input: 25kΩ Outputs: 60Ω balanced, 30Ω unbalanced
Dimension (W x D x H)	483 x 195 x 44 mm (19" x 7.5" x 1.7")
Weight	3.5 kg (7.72 lb)

Specifications subject to modification without notice



SEIKAKU TECHNICAL GROUP LIMITED

NO.1 LANE 17, SEC.2, HAN SHI WEST ROAD, TAICHUNG 40151 TAIWAN

Tel: +886-4-22313737 Fax: +886-4-22346757 www.seikaku.hk